



TECHNICAL DATA

Operating range:

from 0.5 to 6 m³/h with head up to 6.5 metres.

Liquid temperature range:

from 0 °C to 35 °C (EN 60335-2-41).

Installation: fixed or portable, vertical position (max. inclination 10 °).

Free passage of solids: 5 mm.

Automatic start / stop: start 55mm - stop 35mm.

Motor protection class: IP68.

Insulation class: F.

Power input voltage: 230V - 50 Hz single-phase.

APPLICATIONS

Fully automatic submersible electric pump, large support base design to increase stability and the possibility of operation in positions not perfectly perpendicular to the soil.

Built-in float for automatic operation; efficient and maintenance-free pump.

Suitable for winter use on top of swimming pool covers, to remove rain water and prevent the cover itself from breaking due to the heavy weight of the accumulated water.

In case of need, it can become an emptying and draining submersible pump, or a portable pump in emergency cases.

CONSTRUCTION FEATURES OF THE PUMP

Electric pump in resistant thermoplastic material.

Stainless steel motor, shaft, and bolts and screws.

Threefold seal with interposed rings with oil pre-chamber.

Built-in float for automatic operation in inspectionable housing.

Dedicated to seasonal cleaning.

CONSTRUCTION FEATURES OF THE MOTOR

Submersible, asynchronous, continuous service.

Stator inside a stainless steel enclosure, covered by wiring cap and capacitor.

Supplied with 10 m cable and Shuko plug / 10 m cord for positioning on tarpaulin.

Multi rubber connector with clapet valve.

MATERIALS

N.	PARTS*	MATERIALS
1	MOTOR	
	SHAFT	AISI 416 stainless steel
	LINER	AISI 304 stainless steel
3	WASHER	AISI 304 stainless steel
4	IMPELLER	TECHNOPOLYMER
5	NUT	AISI 304 stainless steel
6	O-RING	NBR
7	BASE	TECHNOPOLYMER
8	PUMP BODY	TECHNOPOLYMER
25	O-RING	NBR
26	PUMP COVER	TECHNOPOLYMER
28	FLOAT	TECHNOPOLYMER
29	CLOSING SPHERE	EPDM
33	UPPER BODY	TECHNOPOLYMER
34	HANDLE	TECHNOPOLYMER
35	LOWER BODY	TECHNOPOLYMER
36	SCREW	AISI 304
37	FLOAT INSPECTION COVER	TECHNOPOLYMER

* In contact with the liquid

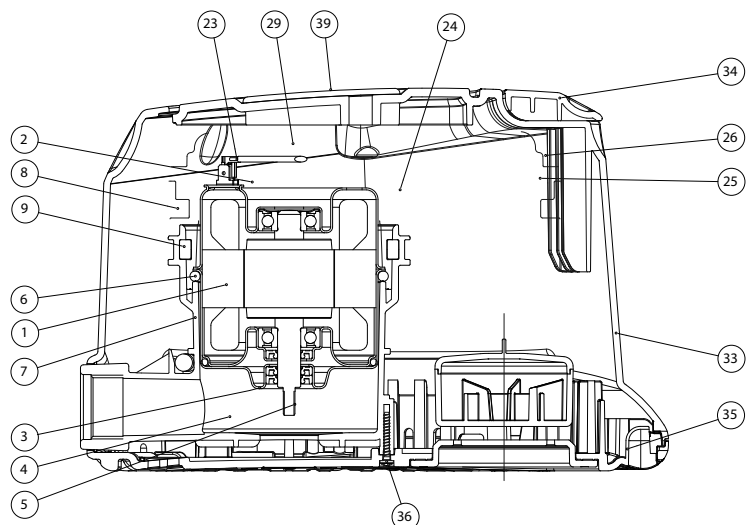

EUROCOVER - SWIMMING POOL COVER SUBMERSIBLE DRAINING ELECTRIC PUMPS

Liquid temperature range: from 0 °C to +35 °C - Maximum ambient temperature: +40 °C

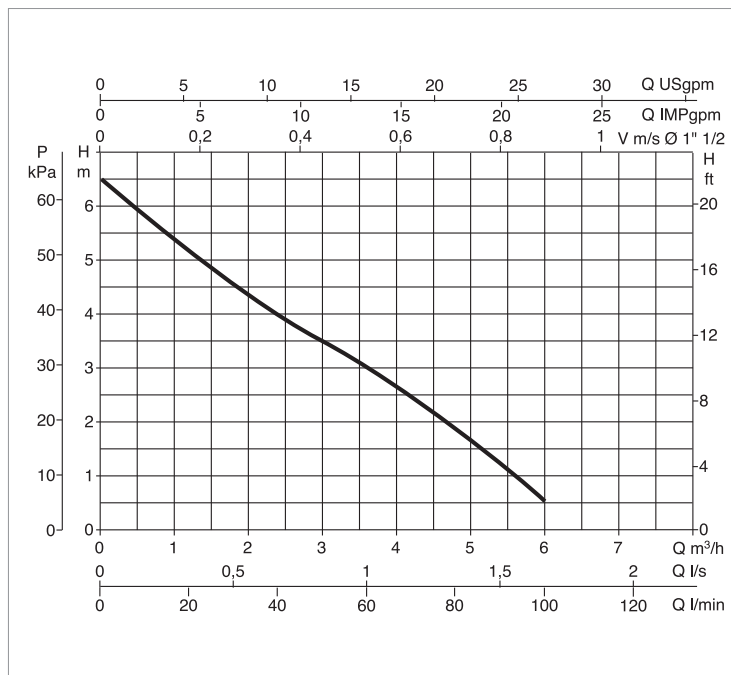
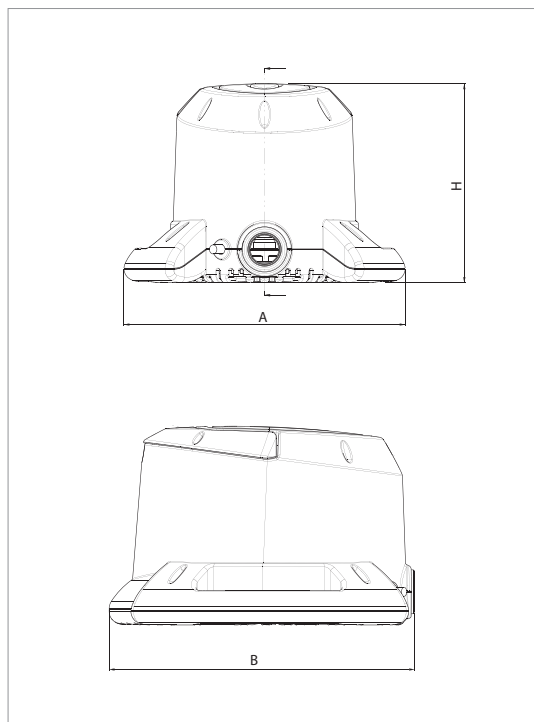

The performance curves are based on kinematic viscosity values = 1 mm²/s and density equal to 1000 kg/m³. Curve tolerance according to ISO 9906.

MODEL	Q= m ³ /h	0	1,2	2,4	3,6	4,8	6
	Q=l/min	0	20	40	60	80	100
EUROCOVER	H (m)	6,5	5,1	4	3	1,9	0,5

MODEL	POWER INPUT 50 Hz	P1 MAX kW	In A	P2 NOMINAL		CAPACITOR	
				kW	HP	µF	Vc
EUROCOVER	230 V ~	250	1,1	0,22	0,3	8	-

MODEL	A	B	H	PACKING DIMENSIONS			WEIGHT kg
				L/A	L/B	H	
EUROCOVER	280,2	304,4	198,1	290	230	320	4,6

